

Motorized Systems for Interior Window Coverings 2009



C
O
M
M
E
R
C
I
A
L

H
O
S
P
I
T
A
L
I
T
Y



R
E
S
I
D
E
N
T
I
A
L

Complete design support and fabrication services of motorized systems; for draperies, horizontal and vertical blinds, cellular, roller and Roman shades.

For retailers, contract/residential architects, designers and specifiers.



Direct Drive Drapery Systems

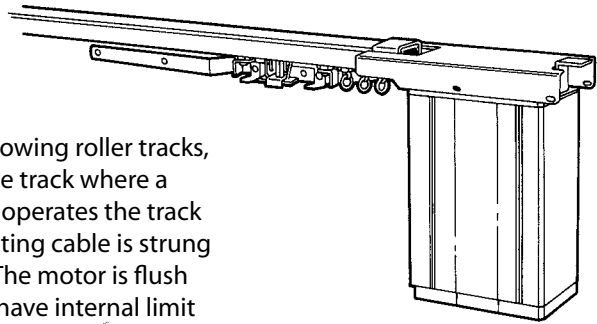

Model 300 Series Drapery Motors, combined with any of the following roller tracks, create a direct drive system. The motor attaches to the end of the track where a shaft on the motor fits into a pulley, which moves the cable and operates the track components. Available as a straight or curved system. The operating cable is strung on the inside of the track on both straight and curved systems. The motor is flush with the front edge of the track. All direct drive drapery motors have internal limit switches, and are available with surface mount or recessed low voltage switches, wireless remote control (radio frequency or infrared), or control system interface. Motors are UL Listed.

	Model 355	Model 370	Model 375
Dimensions (H)x(W)x(D)	6.41" x 4.01" x 2.75"	6.41" x 4.01" x 2.75"	6.41" x 4.01" x 2.75"
Weight	4.1 lbs.	4.5 lbs.	4.6 lbs.
Voltage	115 VAC	115 VAC	115 VAC
Amperage	0.46 A	0.46 A	0.76 A
Cycle	60 Hz	60 Hz	60 Hz
Wattage	60 W	60 W	80 W
Horsepower	0.07 hp	0.07 hp	0.11 hp
Maximum Drapery Weight	44 lbs.	90 lbs.	175 lbs.
Maximum Track Length	25 ft.	50 ft.	65 ft.
Traversing Speed	10 in/sec	10 in/sec	10 in/sec
Thermal Overload	120°C	120°C	120°C
Track Compatibility	30, 90	30, 90	30, 40, 90

Roller Tracks 20, 30 and 40

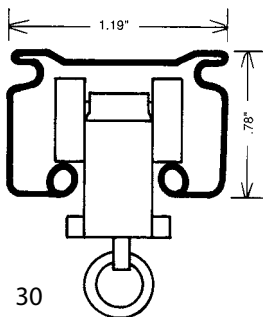

30

30
Steel with white finish

Dimensions: 1.19" x .78" (30mm x 20mm)
Deductions for hanging below track: 1.25"

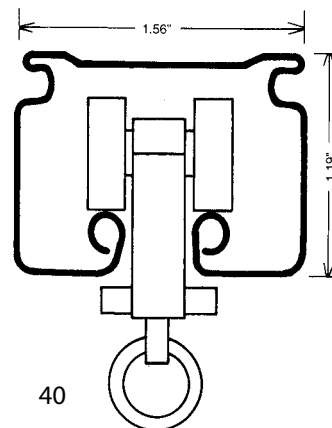

40

40
Steel with silver gray finish

Dimensions: 1.56" x 1.19" (40mm x 30mm)
Deductions for hanging below track: 1.50"

Assembled direct drive roller tracks include: cut-to-measure track, master carriers, roller carriers (3 per foot are standard, with extra carriers at additional cost), end pulleys, ceiling or wall mounting brackets, and cable. Steel tracks are PVC coated inside and out. Roller tracks are also available as cord drawn and hand drawn.

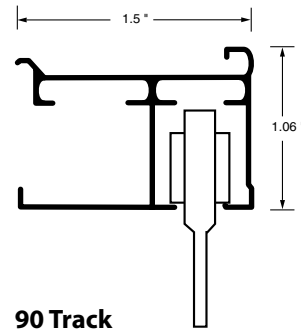
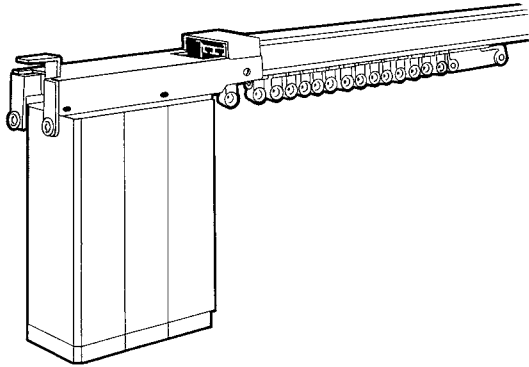

90 Track
Shown with traditional pinch pleat carrier.

SM Automatic also offers the Series 90 Dual Channel track system.

The Series 90 track will accommodate alternative Contemporary pleating styles (often referred to generically as S-fold or Z-fold), as well as traditional pinch (French) pleating.

Pinch pleated draperies may be pinned to either "head up", thereby concealing the track, or hang below the track; while Contemporary pleating styles always hang below the track.

Track is extruded .050" aluminum with white, baked enamel finish.

Available as either ceiling or wall mount.

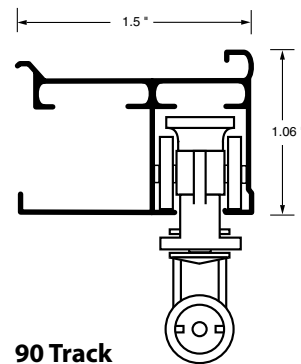

90 Track
Shown with Contemporary pleating carrier.

Curved Direct Drive Drapery Systems

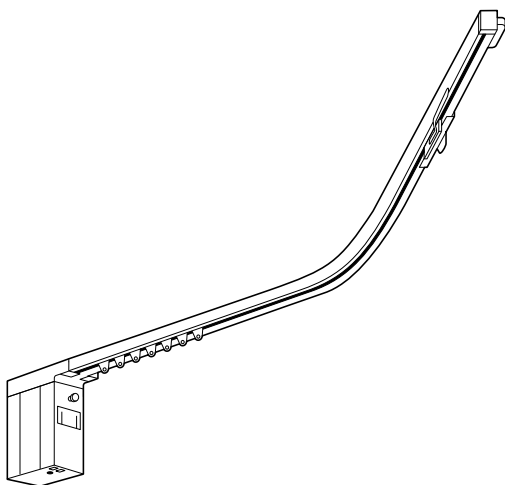

Minimum Radius: 12 inches at 90 degrees

Motorized curved tracks are not available with reverse bends.

Curved systems using Series 90 track

Curved tracks may be either ceiling or wall mounted, and are available as motorized only.

Load capacities for curved systems are listed below.

	Motor	Load Capacity (lbs.)
one curve	370	70
	375	140
two curves	370	60
	375	120
multiple curves	370	50
	375	110
continuous curves	370	70
	375	140

Direct Drive Drapery Systems

Usage

Model 355 Motor:	Light weight draperies
Model 370 Motor:	Light to medium weight draperies
Model 375 Motor:	Light to heavy weight draperies

Specifications

Furnish and install as indicated on drawings and plans, direct drive drapery systems as manufactured by SM Automatic.

Motor shall be located below the track at either the left or right end. Track shall operate as either one way or split draw. Tracks (straight or curved) shall be either ceiling or wall mounted. Motor shall be UL Listed.

All components shall be original SM Automatic. System shall be covered by a three year warranty as published by SM Automatic. Consult wiring diagrams for electrical wiring information.

Sample System Specifications

Model 355/90 motorized drapery system: motor 355 / track 90

Motor (355) shall have dimensions 6.41" x 4.01" x 2.75", and have both internal limit switches and thermal overload switch. Motor will operate at 115 volts AC, 0.46 amps, 60 Hz, 60 watts. Motor shall traverse at 10 inches per second. Track shall have exterior dimensions of 1.50" x 1.0625" and be operated by plastic coated steel cable. Track shall be extruded aluminum with white baked enamel finish.

Model 370/30 motorized drapery system: motor 370 / track 30

Motor (370) shall have dimensions 6.41" x 4.01" x 2.75", and have both internal limit switches and thermal overload switch. Motor will operate at 115 volts AC, 0.46 amps, 60 Hz, 60 watts. Motor shall traverse at 10 inches per second. Track shall have exterior dimensions of 1.19" x 0.78" and be operated by plastic coated steel cable. Track shall be PVC coated white roll formed steel.

Cord Drive Drapery Motor

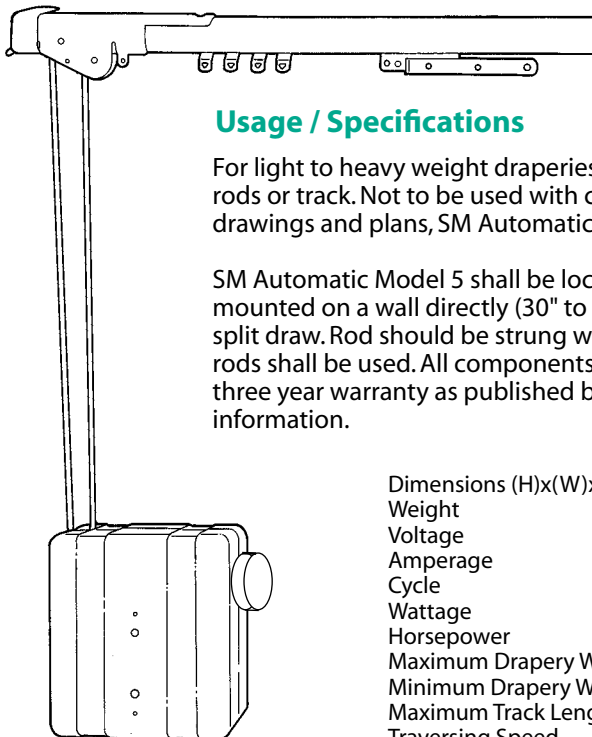

Usage / Specifications

For light to heavy weight draperies, and designed to be used with cut-to-measure corded straight rods or track. Not to be used with curved rods or tracks. Furnish and install as indicated on drawings and plans, SM Automatic cord drive drapery motor.

SM Automatic Model 5 shall be located below the rod/track at either the left or right end, typically mounted on a wall directly (30" to 108") beneath the rod. Rod shall operate as either one way or split draw. Rod should be strung with either #3-3/4 wire center cord, or SM PPV cord. Only straight rods shall be used. All components shall be original SM Automatic. Motor shall be covered by a three year warranty as published by SM Automatic. Consult wiring diagrams for electrical wiring information.

Dimensions (H)x(W)x(D)	5.75" x 5.70" x 3.00"
Weight	6.0 lbs.
Voltage	110 VAC
Amperage	0.6 A
Cycle	60 Hz
Wattage	66 W
Horsepower	0.09 hp
Maximum Drapery Weight	100 lbs.
Minimum Drapery Weight	15 lbs.
Maximum Track Length	40 ft. (center open)
Traversing Speed	7 in/sec
Thermal Overload	120°C

Low Voltage Modular Switch (recessed wall installation)

A specially designed three button switch which allows stopping or direction reversal at any point. The switch conforms to a single gang junction box. Low voltage switching connections are made from the switch port of the motor to a modular wall RJ-11 (phone type) connector; then inside the wall to the junction box containing the switch. Low voltage 4 conductor (22/4) wire run within the wall, is typically supplied by the electrician. Power is supplied by a 9 foot power cord.

Low Voltage Modular Switch (hand held or surface mount)

As above, but simply comes with a 12 foot, low voltage cord that plugs into a switch port of the motor.

Radio Frequency Wireless Remote Control (RF)

Transmitter are available in configurations to operate from 1 - 24 motors, with individual and group control capabilities.

Infrared Wireless Remote Control (IR)

A wide variety of configurations are possible, allowing for either individual or group operation. A receiving eye is plugged into the receiver using a modular cable, and takes it's signal from the transmitter; which are available in configurations to operate from 1 - 24 motors.

Electrical information for all other motors is on page 8.

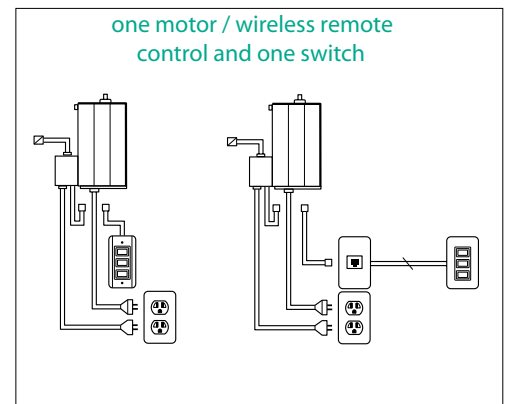
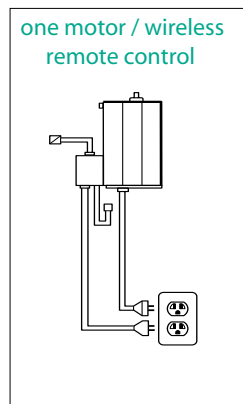
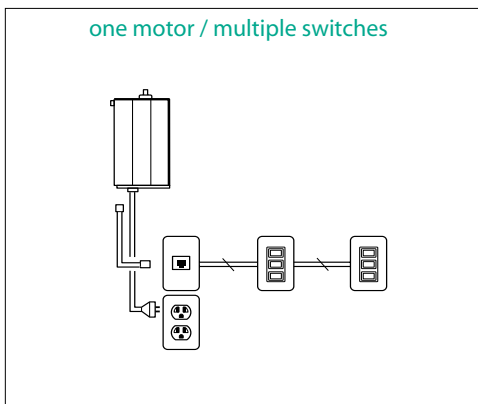
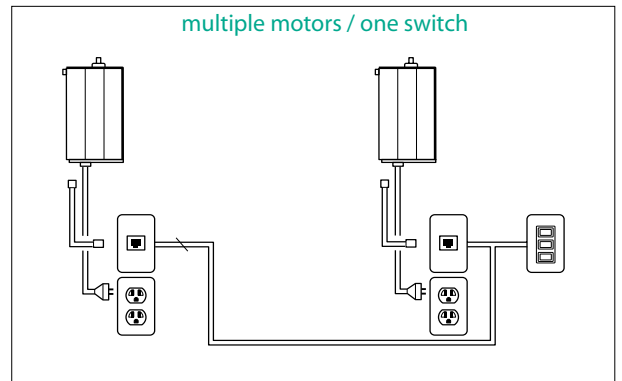
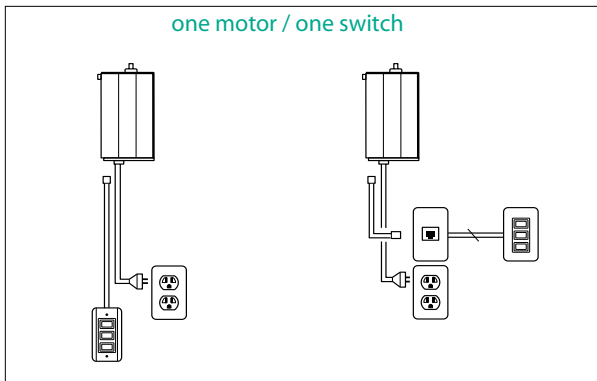
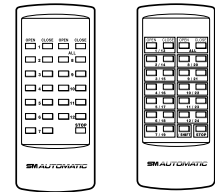
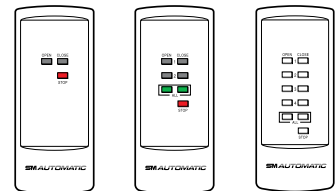
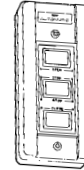
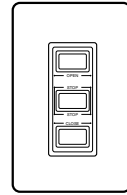

Model 5100 Motorized Vertical Blind System

Usage

This system features a single heavy duty motor to control both rotation and traversing functions. The aluminum head rail will accommodate 3.5" or 5" vanes, and can be either ceiling or wall mounted. Recommended applications include: residences, offices, hotels, hospitals, and schools.

Specifications

Furnish and install as indicated on drawings and plans, Model 5100 as manufactured by SM Automatic. System shall be covered by a three year warranty as published by SM Automatic. Motor shall be UL Recognized. Consult wiring diagrams for electrical wiring information.

Track shall be extruded aluminum with dimensions 1.75" (W) x 2.00" (H) and a wall thickness of .05". The maximum track length shall be 276" using 5" vanes and 180" using 3.5" vanes. Maximum weight per vane is 1.5 lb.

The motor shall be located at either end and shall be mounted to the rear of track. The motor shall have the following specifications:

Dimensions (W)x(H)x(L)	2.375" x 2.00" x 8.00"
Voltage	110 VAC
Amperage	.26 A
Cycle	60 Hz

Watts	30 W
Horsepower	0.04 hp
Maximum Load Capacity	70 lbs.
Traversing Speed	2 in/sec
Maximum Weight per Vane	1.5 lbs.

Installation

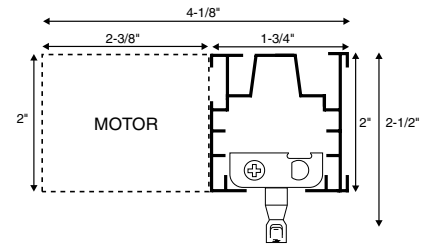
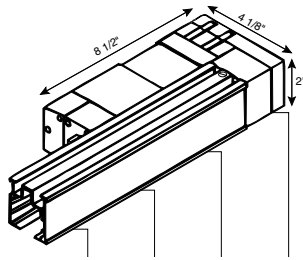

Model 8000 Motorized Horizontal Blind System

Usage

A single motor with planetary gears for both lift and tilt operations. Available with 1" or 2" aluminum slats, as well as 1", 2" or 3" wood slats. Limit switches are adjustable for top and bottom positions. The system includes slat material; which may be specified from virtually any national manufacturer, such as Levolor, M&B, Mark Window, and HunterDouglas. Recommended applications include: residences, offices, hotels, hospitals, and schools.

Specifications

Furnish and install as indicated on drawings and plans, Model 8000 as manufactured by SM Automatic. System shall be covered by a three year warranty as published by SM Automatic. Motor shall be UL Recognized. Consult wiring diagrams for electrical wiring information.

Head rail Dimensions (W)x(H)	2.65" x 2.65"
Head rail Size Minimum	28"
Head rail Size Maximum	192"
Overall Blind Size Maximum	240 sq. ft.

Voltage	110 VAC
Amperage	0.9-1.25 A
Cycle	60 Hz
Watts	126 W
Horsepower	0.17 hp
Lift Speed	2 in/sec

Installation

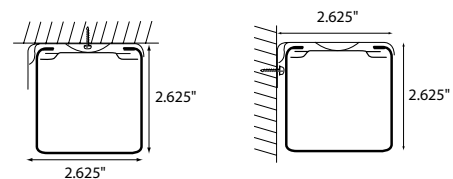
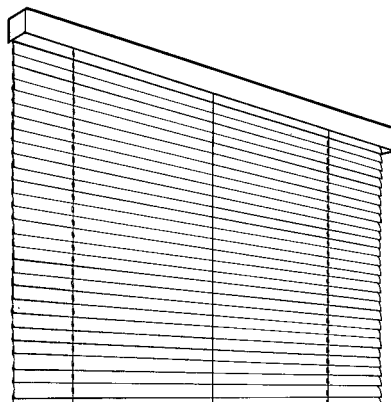

Brackets may be either ceiling or wall mounted.
Additional bracket styles are available.

Usage

Designed to lift pleated, cellular, Roman, Austrian, and balloon shades; as well all typically cord operated shades. The motor and operating hardware are concealed inside the slim head rail. With pleated or cellular shades, the shade head rail is attached to the bottom of the Model 9600 head rail. In both cases the shade cords are replaced by flat tape to provide even lifting operation. Complete systems including Duette® and other popular cellular shades are available. **Now including the SMART™ System, an SM Automatic Exclusive, that prevents obstruction related system failure.** Recommended applications include: residences, offices, hotels, and conference rooms.

Specifications

Furnish and install as indicated on drawings and plans, Model 9600 as manufactured by SM Automatic. System shall include motor, motorization components, head rail, and brackets. System shall be covered by a three year warranty as published by SM Automatic. Motor shall be UL Recognized. Consult wiring diagrams for electrical wiring information.

Head rail dimension (W)x(H)	2.65" x 2.65"	Voltage	110 VAC
Maximum Load*	40 lbs.	Amperage	0.9-1.25 A
Maximum System Width	197"	Watts	125 W
Minimum System Width	20"	Cycle	60 Hz
Maximum Shade Height	192"	Horsepower	0.17 hp
		Lift Speed	2 in/sec

Installation

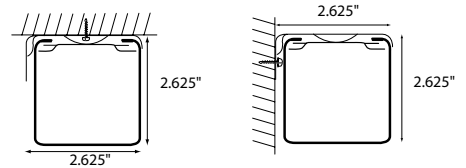
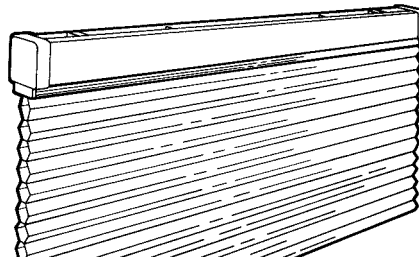

Brackets may be either ceiling or wall mounted. Additional bracket styles are available.

*Duette is a registered trademark of HunterDouglas, Inc.

Model 9300 series Motorized Lift System

Usage

Designed to lift Roman shades, Austrian poufs, balloon shades, and all typically cord operated shades; as well as roller shades. Blackout and sunscreen roller shades are available as an option for a complete shade system. Adjustable limit switches for automatic stopping at top and bottom positions. Concealment of system is recommended by using a valance, cornice, or placement in a recessed cavity. For typically cord operated shades, cords are replaced by 6mm flat tape with take-up reels to provide even lifting operation. Recommended applications include: residences, offices, hotels, conference rooms, and schools

Specifications

Furnish and install as indicated on drawings and plans, Model 9300 series (9310, 9320, 9330, or 9340) as manufactured by SM Automatic. System shall include motor, tubing and brackets (as well as optional take up reels when applicable). System shall be covered by a three year warranty as published by SM Automatic. Motor shall be UL Recognized. Consult wiring diagrams for electrical wiring information.

Tube Dimensions	2" diameter (OD)*	Voltage	120 VAC
Maximum System Width	144" (one piece)**	Amperage	.9-1.7 A
Minimum System Width	22.75"	Watts	140-260 W
Maximum Shade Height	228"	Cycle	60 Hz
RPM	38	Horsepower	0.2 - 0.35 hp

*Roller shade motorized systems are also available with 1.5" and 2.75" diameter tubes

**Maximum width is 480" using connector supports

Installation

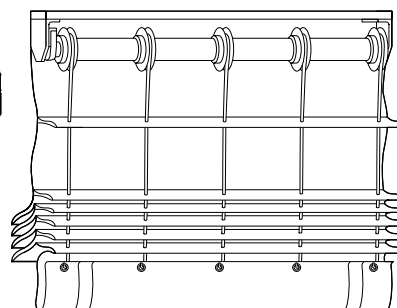
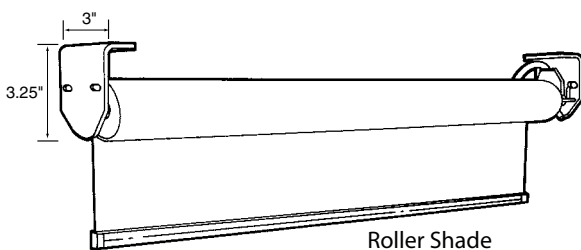

Model	Load Capacity
9310	30 lbs
9320	50 lbs
9330	80 lbs
9340	120 lbs

Hard Wiring (HW)

All motors come with a 4 wire grounded pigtail. This consists of a neutral, two directional wires and a ground. This type of wiring is used when the motor is to be controlled by a recessed wall switch. The pigtail is connected by either hard wiring or a plug/receptacle. A single motor is controlled by an SPDT (single pole, double throw) switch. Two motors can be controlled together by a DPDT (double pole, double throw) switch. When more than two motors are to be controlled by a single switch, parallel relays are required for each motor.

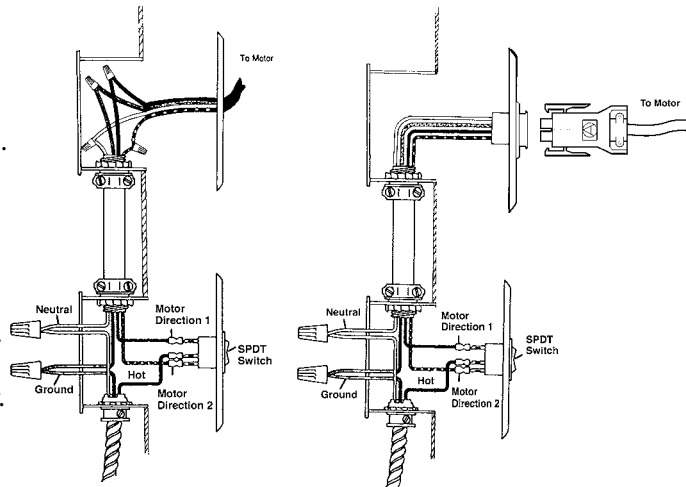

Hard Wiring with Isolation Relays (HW/ISO)

This variation of hard wiring is used when controlling two or more motors simultaneously from a single SPDT switch. Each motor's pigtail (with relay incorporated) is connected either by hard wiring or by plug/receptacle to an individual junction box. The wiring from each junction box is connected from one to the next; with the wiring from the terminal junction box being connected to the switch.

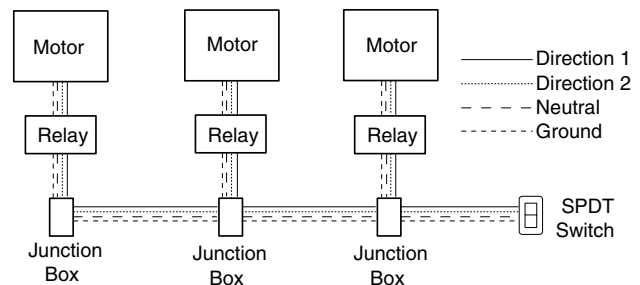

Radio Frequency Wireless Remote Control (RF)

This system requires only a single 110 VAC power cord, which powers the motor, as well as the remote control receiver. A wide variety of configurations are possible, allowing for either individual or group operation; as well as auxiliary wall switches and A/V control interfaces. Transmitters are available in configurations to operate from 1 - 24 motors.

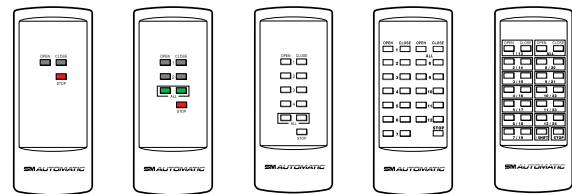

Infrared Wireless Remote Control (IR)

This system requires only a single 110 VAC power cord, which powers the motor, as well as the remote control receiver. A wide variety of configurations are possible, allowing for either individual or group operation; as well as auxiliary wall switches and A/V control interfaces. A receiving eye is plugged into the receiver using a modular cable, and takes its signal from the transmitter; which are available in configurations to operate from 1 - 24 motors.

Electrical wiring required
for either RF or IR wireless
remote control,

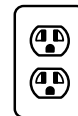

is a standard 110 VAC duplex
electrical outlet.

All specifications found within are subject to change without notice.

