

# Estate™ Traverse Rod System

## 2" Estate™ Assembled Set

### TRACK STYLE

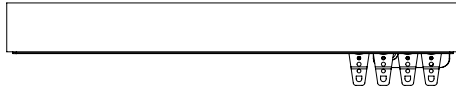

### DIMENSIONS FOR 83601

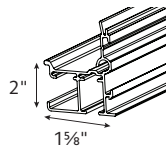

### DIMENSIONS FOR 93601

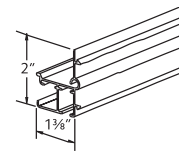

### Track Overview

- Briza™ Motorization available
- Assembled sets includes all necessary components
- Heavy duty, ball bearing pulleys
- Heavy duty, wheeled (Ripplefold™) or ball bearing (pleated) carriers
- Wall or ceiling mount available
- Multiple draw options available; cord, hand/baton, Briza™ Motorization

### Available Colors

\*93601 available only in anodized and bronze.



White



Anodized



Bronze



Black

### Available Draw Types



Hand



Baton



Cord



Motorized

### Specifications

PROFILE	DESCRIPTION	HEADING STYLE	MOUNT	DRAW	MAX. TRACK SET LENGTH (FT.)	MAX. FABRIC WEIGHT (LBS.)		LBS. PER FT.	
	93601 2" Estate™ for Rounded Fascias	Pleated, Ripplefold™	Ceiling, Wall	One-Way	16	Cord, Hand/Baton		64	4
				Two-Way	16	Briza™		100	6.25
	83601 2" Estate™ for Chroma and Varia Fascias			One-Way	16	Cord, Hand/Baton		64	4
				Two-Way	16	Briza™		100	6.25

Maximum track lengths and maximum fabric weights do not apply to curved tracks. Send complete specifications to customer service for feasibility.

### Installation for Standard Mount

Install according to instructions.

#### 2" WALL MOUNT

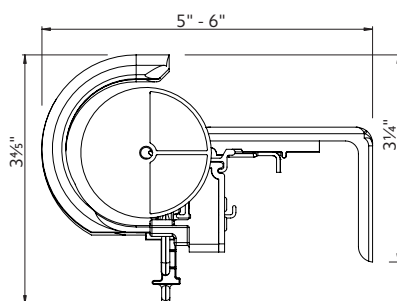

#### 2" CEILING MOUNT

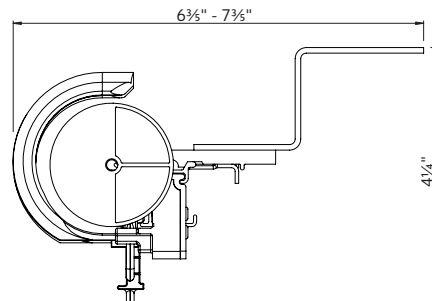

#### SUPPORT SPACING

Two brackets at each end 24" apart, 48" intervals over the remainder of track. Spacing may need to be shortened for heavier draperies.

# Installation for Double Mount

**2" DOUBLE MOUNT**

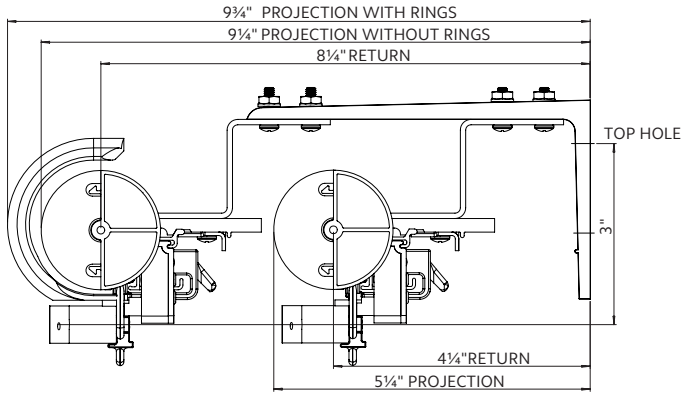

**2" DOUBLE STAGGERED MOUNT**

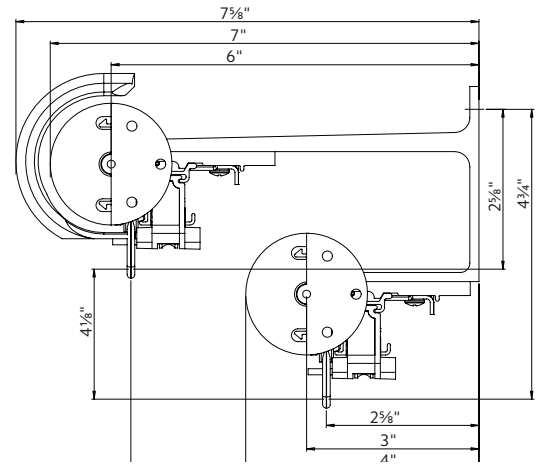

**2" DOUBLE MOUNT WITH SUPERFINE™**

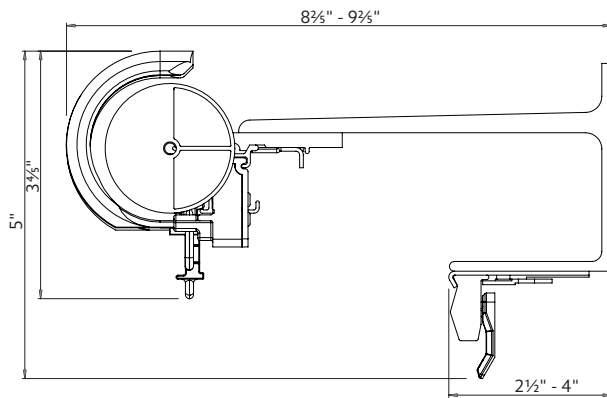

**2" & 1 3/8" DOUBLE STAGGERED MOUNT**

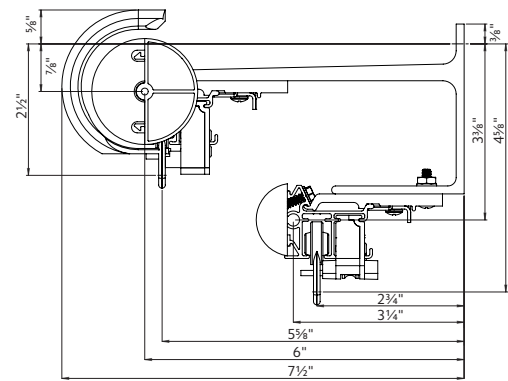

**2" & 1 3/8" DOUBLE MOUNT**

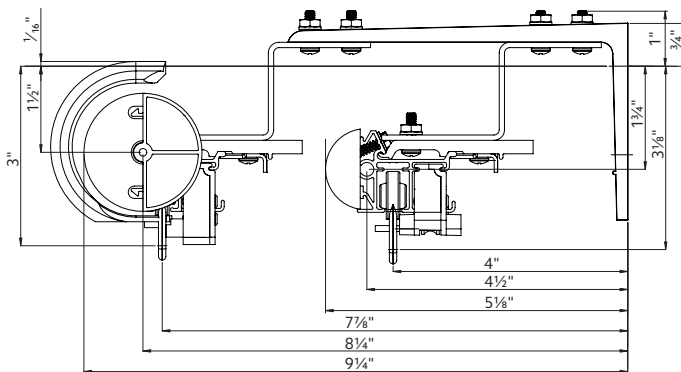

**2" DOUBLE MOUNT WITH ARCHITRAC® SERIES 94001**

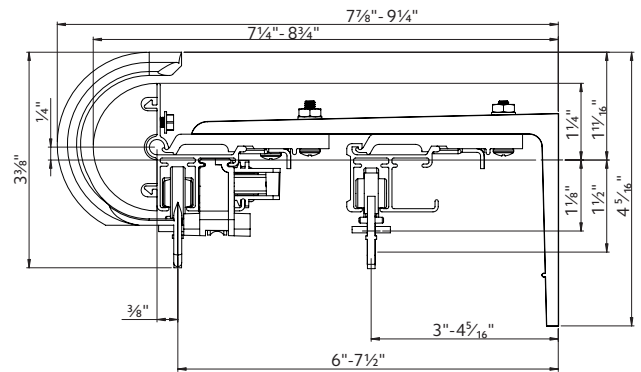





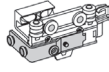

**SUPPORT SPACING**

Two brackets at each end 24" apart, 48" intervals over the remainder of track. Spacing may need to be shortened for heavier draperies.

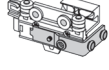
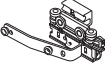
# Track Components

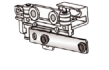
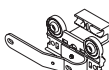
## Wheeled Master Carriers

ITEM	PRODUCT NUMBER	NOTES
	<b>Buttmaster Carriers</b> Right 84101 Heading Style: Pleated, Ripplefold™ Color: 061 Zinc, 059 Black	Drapery panels butt together at center, no flat areas to overlap 
	<b>Buttmaster Carriers</b> Left 84102 Heading Style: Pleated, Ripplefold™ Color: 061 Zinc, 059 Black	
	<b>Overlap Carriers</b> Right 84103 Heading Style: Pleated, Ripplefold™ Color: 061 Zinc, 059 Black	Drapery panels overlap at center 
	<b>Overlap Carriers</b> Left 84104 Heading Style: Pleated, Ripplefold™ Color: 061 Zinc, 059 Black	
	<b>Overlap Carriers   Ball Bearing</b> Right Heading Style: Pleated Color: 93706055 Light Gray, 1856960 Satin Nickel 1856971 Brushed Bronze, 1856959 Black	
	<b>Overlap Carriers   Ball Bearing</b> Left Heading Style: Pleated Color: 93707055 Light Gray, 1856975 Satin Nickel 1856976 Brushed Bronze, 1856974 Black	







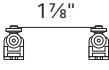

## 2" Ball Bearing Wheeled Carriers

ITEM	PRODUCT NUMBER	NOTES
	<b>25mm Ball Bearing Carriers</b> 9680 Color: 025 White	For use with Estate™ Decorative Rings

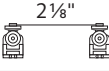
## 2" Ball Bearing Wheeled Carriers

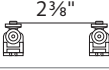
ITEM	PRODUCT NUMBER	NOTES
	<b>16mm Ball Bearing Carriers</b> 86700 Color: 025 White, 061 Gray, 064 Bronze, 059 Black	

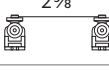
## Ripplefold™ Wheeled Carriers

ITEM	PRODUCT NUMBER	NOTES
 17/8"	<b>120% Ripplefold™ Carriers</b> 82120 Color: 025 White, 059 Black	
 2 1/8"	<b>100% Ripplefold™ Carriers</b> 82100 Color: 025 White, 059 Black	
 2 3/8"	<b>80% Ripplefold™ Carriers</b> 82080 Color: 025 White, 059 Black	
 2 5/8"	<b>60% Ripplefold™ Carriers</b> 82060 Color: 025 White, 059 Black	
	<b>Two Sides Snap Pendant</b> 82001 Color: 025 White, 061 Gray, 064 Bronze, 059 Black	To be used with Ripplefold™ wheeled carriers. (82120,82100,82080,82060)